



FIELD EXPERIENCE WITH ON-LINE DC BUSHING MONITORING IN HVDC SYSTEM AT IBIÚNA SUBSTATION

EDILSON G. PERES*

Furnas Centrais Elétricas S.A.

Brazil

MARCOS E. G. ALVES**

Treetech Sistemas Digitais Ltda.

Brazil

Substract: The on-line capacitance and AC bushing delta tangent monitoring has reached good results in its application on power reactors and transformers. However, its direct application in converter transformer condensive bushings, with the use of the same hardware and software resources, is not possible, because of the presence of harmonic that results from the conversion from continuous to alternated current, in the bushings of this equipment. The present essay will show the results obtained on the development of on-line condensive bushing monitoring applied to converter transformers bushings of Ibiuna Substation.

Key words: converter transformer, on-line monitoring, bushing, capacitance, delta tangent.

I – INTRODUCTION

Ibiuna Substation is the converter terminal where all the energy produced in 50 Hz in Itaipu Hydroelectric, after its conversion into continuous current in Foz do Iguacu Substation and transmitted in $\pm 600\text{kV}$ DC, is converted into alternated current, now in 60 Hz, 345kV AC, and is flowed to the Brazilian interlinked system.

With an installed capacity of 7200 MVA, Ibiuna Substation has 24 converter transformers in operation. These transformers are 300 MVA monophase units, with a primary winding and two secondary windings. Every three monophase units makes a converter, every pole is constituted of two converters and every bipole is constituted of two poles (picture 1).

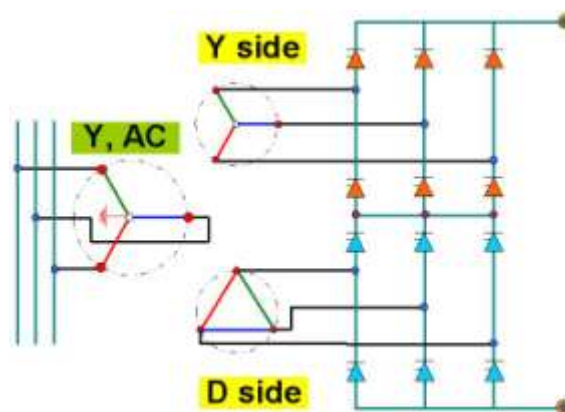

Picture 1: trifilar chart of three monophase units making a converter

To meet the 12 pulse converter necessity the X1 and X2 windings of each transformer which makes a converter are connected in star and the X3 and X4 are connected in delta (picture 1). The H1-H01 and H2-H02 windings are connected in landing star. A chart of converter transformer bushings disposition is presented in picture 2.

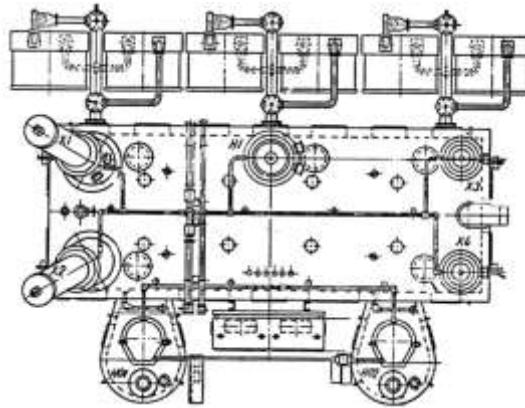

Picture 2: converter transformer bushings disposition

II – HVDC BUSHING ON-LINE MONITORING

II.1 – CONDENSIVE BUSHINGS CONSTRUCTION SHAPE

The bushings of a condensive type have their active part constituted of several concentric cylindrical isolating layers, intercalated with conductive layers, also cylindrical, which function is to uniform to the fullest the electrical field. The most external conductive layer is connected to the bushing flange and this one to earth. The intermediate conductive layers keep on isolated with flowing potential, except one of the most external, which is landed through a removable link next to the bushing base called voltage tap, test tap or simply tap (picture 3). For application in the environment, this group called condensive body will be in an impermeable container, which could be of porcelain, silicon or any other polimeric material made of silicon.

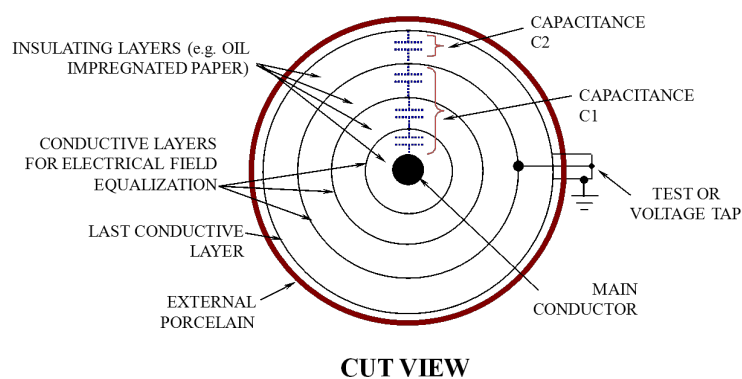

Picture 3- condensive bushing construction shape

The group described above acts electrically as several capacitors connected in series, forming a capacitive voltage divise. This way, the main conductor total potential difference in relation to the land is divided among the several capacitors. An equivalent circuit of an energized bushing is shown on picture 4.

Condensive Bushing Construction

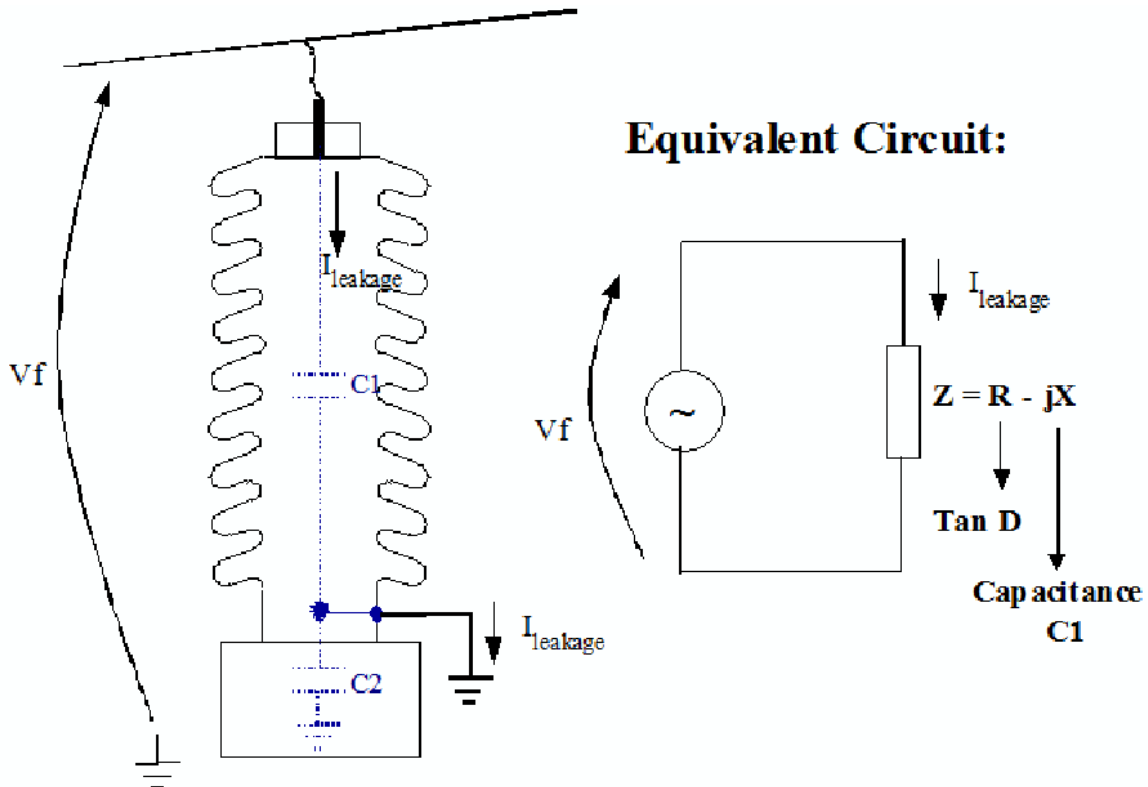

Picture 4- equivalent circuit of an energized bushing

When a phase-land voltage is applied to the bushing of a current, called stray current, it starts circulating through its isolation mainly due to its capacitance and in far lower proportion due to its dielectrical losses (expressed by the dissipation factor or delta tangent). Picture 4 illustrates this situation; on this picture we can see the electrical equivalent obtained from the construction shown on picture 3 with the bushing already energized. This is the equivalent electrical model “series”. A “parallel” electrical model could be also applied with the same results. With the adopted model, we have the following resulting stray current:

$$I_{fuga} = \frac{V_f}{Z} = \frac{V_f}{R - jX}$$

where R represents the resistive component of the isolating impedance which is associated to the resistive part of the stray current and, consequently, the dielectrical losses. The X component is associated to the isolating capacitance.

II. 2 – ON-LINE MONITORING OPERATION PHYLOSOPHY

The goal of on-line condensive bushing monitoring is to detect bushing isolating changings even in its initial phase indicating the development of the conditions that could lead to equipment dielectrical flaw. For that, it is necessary to detect, with the energized bushing, changings in capacitance and/or isolation delta tangent, in other words, changings in “Z” impedance of isolation bushing.

In each bushing the stray current (I_{stray}) flows through C_1 capacitance to earth passing along the tap. Observe that according to the circuit presented before, this current is function of the phase-land voltage and the isolation impedance. This way, any changing in isolation impedance (capacitance or dissipation factor) will be reflected in a correspondent changing in the stray current which, in theory, could be used for the detection of changing taken place in the impedance.

However, one of the obstacles found for the detection according to what had been described above is the changing quantity we would like to monitor. Such small changes as an algebraical increase of 0,3% in the dissipation factor [1] of a bushing can represent the difference between a new bushing, in good conditions, and a bushing in the edge of the acceptable. It is evident that such a small changing in the dissipation factor will cause a practically insignificant changing in the bushing stray current, making unviable its detection through the stray current of each bushing monitoring only.

One of the techniques that allows the overcoming of this practical limitation quoted is the use of the vectorial sum of the stray current in the three bushings in a three-phase system. In such an arrangement the three stray currents are dephased among them in approximately 120° electric and, normally, they have the same magnitude, because the three bushings have similar capacitances, in principle, and the voltage on the three phases are close to balance. With that, the sum of the three stray currents tend to a figure lower than the stray current considered individually, as illustrated on picture 5a for a given initial condition of capacitances and dissipation factors.

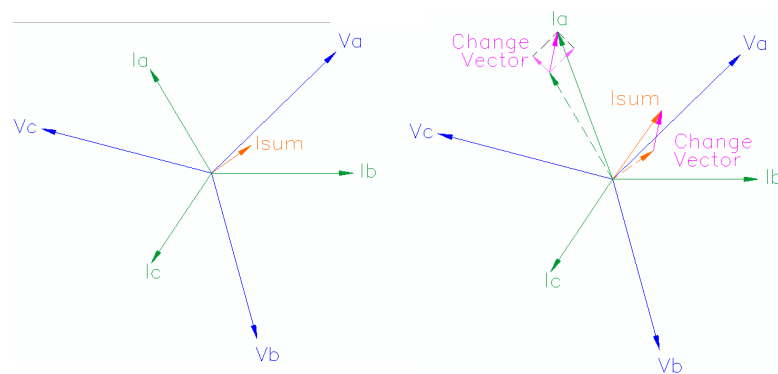

Picture 5 - Stray currents of three bushings in a three-phase system and their sum: (a) for a given initial condition. (b) with changing in phase A bushing capacitance and dissipation factor.

Let us suppose now that there is a changing in the phase A bushing capacitance and dissipation factor as shown on picture 5b, the changing vector (ΔI) which expresses the I current shifting from its initial figure to its final figure, is reflected in the current sum as well which is changed in relation to its initial figure according to the same changing vector (ΔI).

$$\Delta I = I_a(\text{atual}) - I_a(\text{anterior}) = I_{\text{soma}}(\text{atual}) - I_{\text{soma}}(\text{anterior})$$

This changing vector is almost insignificant when compared to the phase A stray current quantity. But the same does not occur when this vector is compared to the current sum which allows its detection and, therefore, the detection of changing taken place in this bushing impedance.

As for the exposed above, we see some intrinsic characteristics to the method used:

- It is necessary to determine an initial reference of currents for the system to later on compare them to the new on-line measurings in a way to determine the changings occurred in the bushings capacitance and dissipation factor;
- Bushings delta tangent and capacitance absolute figures measurings are not done, but the variation measurings occurred in these parameters. But as far as each bushing delta tangent and capacitance initial figures are known (given figures at the moment current initial references are determined) the measuring of variations occurred allows to know the present figures of capacitance and delta tangent;
- In case of new bushings, we can use as initial figures of capacitance and delta tangent the plaque figures determined by the bushing manufacturer. But for the bushings already in operation it is advisable that, in on-line monitoring system installation, measurings of these parameters be done through conventional methods, with non-energized bushings. With that we guarantee the correct initial figures have been used by the monitoring system.



II.3 – THE ON-LINE BUSHING MONITORING APPLIED TO HVDC BUSHINGS

The AC/DC conversion process is inevitably followed by harmonic generation effects, the odd ones generated in the AC side and the even ones generated in the DC side. As a consequence, the wave shape of the stray currents which shows up in X1, X2, X3 and X4 bushings of the converter transformers have the aspect illustrated on picture 6:

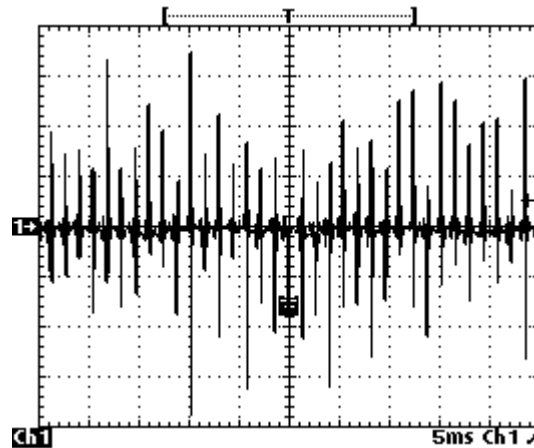

Picture 6: Stray current wave shape in X₁, X₂, X₃ e X₄ bushings

Such fact makes impossible the direct application, in HVDC bushings, of the monitoring system with the same software and hardware resources used in AC bushings monitoring.

In the first moment, direct application of monitoring system for AC bushings had been tried on HVDC bushings, but with no success.

Later on, a changing in data aquisition software was carried out, but this changing was not enough to allow the monitoring system to read the stray current correctly.

Finally, together with the changing in data aquisition software, a changing in hardware was also done. Such changings allowed the monitoring system to make the aquisition and interpretation of the (stray current) signal coming from the bushing tap.

II.4 – ON-LINE MONITORING SYSTEM SAFETY

As exposed on item II.2, the stray current and the current sum are influenced not only by the bushings capacitance and delta tangent changings, but by phase-land voltage changings in each bushing as well. This influence is eliminated through mathematical and statistical treatments carried out in the measurings, that is why the determination process of current initial reference is done in an adjustable period of time from 1 to 7 days after the monitoring system operation starts. As for the changing measuring process occurred, for the same reasons, there is an answering time constant of the same magnitude.

The bushing physical construction originates capacitive voltage divisive as shown before, and the bottom portion of this divisive normally under short-circuit, landing the bushing tap in a way that its voltage related to the land is zero Volt. To be possible the bushing stray current measuring this landing turns out to be done through the stray current measuring circuit. Due to the low impedance of this circuit, the tap voltage related to the land keeps close to zero. However, in case of measuring circuit accidental interruption, the capacitive voltage divisive would generate a voltage in the bushing tap which is normally over the tap dielectrical stiffness related to the land, with damage risks to the bushing. To avoid this occurrence, the connection adaptor to the bushing tap is provided with two voltage limitator devices, connected in parallel in a redundant



configuration. These devices start conducting in case of measuring circuit opening, making a way of low impedance for the stray current in a way that the tap voltage in relation to the land keeps on a few Volts. The voltage limiter devices are not susceptible to electrical or mechanical wearing, which allows each one of them separately conduct for an undetermined period of time, at least, 2,5 times the maximum stray current found in several bushing models that exist.

Besides, the voltage limiter devices act as protection against overload and overvoltage which are developed in the bushing tap when transitory overvoltage occurs in the electrical system. It also allows that all dielectrical tests (for example, impulse voltage) are done on bushings already with the on-line monitoring system connected and in operation.

II.5 – INSTALLATION

The bushing monitoring system used has a modular conception, constituted of 3 basic parts:

- tap adaptors (picture 7) – provide the bushing tap electrical connection, guaranteeing its impermeability against bad weather as well. It embraces the redundant protections against accidental opening of the measuring circuit and so avoiding that the tap keeps on open.



Picture 7: tap adaptor

- Measuring Modules – receive stray currents from three bushings in a three-phase group, measure these currents and their mathematical and statistical processing, making them available to the interface module the capacitance and delta tangent present figures through a serial communication door.



Picture 8: measuring modules



- Interface Module – receives the information from the measuring modules and make it available in local way in its display and remotely through the alarm output contacts, analogical outputs (mA) and serial communication doors. Optionally, the interface module can be connected to the company's Intranet, to remote access to the measurings as well.



Picture 9: interface module

Six GOE 1950, six GOE 1425 and three GOE 1175 bushings have been monitored in Ibiuna Substation.

Two interface modules and five measuring modules have been used to make the monitoring of Ibiuna Substation converter transformer 4. These modules have been installed in the ZM.1.C transformer individual panel. The data acquired by the measuring modules are sent to a server, where the monitoring software is installed, through a wireless communication of a Wi-fi type.

III - CONCLUSION

As far as we know, the on-line monitoring system application in HVDC bushings is pioneer. And this essay has showed the functioning principle which allows the on-line monitoring of these bushings as well as the system's application experience to Ibiuna Substation converter transformer bushings.

As for this pioneering system, we know it still needs some improvement and that, for sure, will bring benefits such as:

- Reduction in equipment flaws.
- Reduction or elimination of off-line tests on bushings.
- Increase in transformers availability for the electrical system by the reduction of stops for preventive maintenance.
- Reduction in maintenance costs.

IV - BIBLIOGRAPHICAL REFERENCES

- (1) Alves, Marcos; Melo, Marcos, "Experience on On-Line Capacitance and Delta Tangent Condensive Bushings Monitoring", XIX SNPTEE, October/2007.
- (2) The Institute of Electrical and Electronic Engineers, ANSI/IEEE Std C57.19.100-1995, "IEEE Guide for Application of Power Apparatus Bushings", March/1995.
- (3) Alves, Marcos, "On-Line Condensive Bushings Monitoring System", Eletricidade Moderna Magazine, April/2005.
- (4) Alves, Marcos; Zanetta, Luis, "Monitoring on Thermal Condensive Bushing Aging Isolated with Paper Impregnated with Oil", X SEPOPE, May/2006.
- (5) Alves, Marcos, "On-Line Power Transformers Monitoring System", Eletricidade Moderna Magazine, May/2004.



V - BIOGRAPHICAL DATA

Edilson Gonzaga Peres, born in Lorena, SP, on 3rd January, 1974, has worked at Furnas Centrais Elétricas since 2004. Electro-Mechanical Engineer at Ibiuna Substation, graduated as Electric Engineer in 1999 at Itajubá Federal Engineering School (EFEI).

Marcos E. Guerra Alves, born in Rio de Janeiro, RJ, on 15th July, 1975, has worked at Treotech Sistemas Digitais since 1992. Specialized in Power Transformers Monitoring and Control Systems, he is the Development and Research Department Manager. He graduated as Electric Engineer in 2001 at São Judas Tadeu University, São Paulo, and in 2005 finished attending Mastership in Automation and Energy at São Paulo University (USP).