



Experience with Voltage Regulation in Mixed Networks Using Multi-Parameter Relays

Eng. Eduardo Carraro
Elektro S.A
eduardo.carraro@elektro.com.br

Eng. Carlos Benedik
Elektro S.A
carlos.benedik@elektro.com.br

Eng. Marcos E. G. Alves
Treetech Sistemas Digitais
marcos.alves@treetech.com.br

SUMMARY

Resolution ANEEL 505 made voltage supply limits even stricter. As a result, voltage regulation in some of ELEKTRO's facilities was difficult, and satisfactory results were not being obtained with conventional regulation relays due to the association with long lines feeding industrial and residential loads, which may lead to low voltages when the industrial sector is operating in light load regime and the residential segment, operating at full load, such as on Sunday peak times.

This paper presents the results of a partnership between ELEKTRO and a relay manufacturer that resulted in the development of a relay that operates with multiple adjustment groups, programmed for automatic operation on specific times of the day and for certain days of the week ranges.

The paper brings the experiences with this relay in the regulation system for a 138/34.5kV S/S, which feeds a 34.5/13.8kV 18.75MVA S/S approximately 20km away which features fixed tap adjustment, fact which makes creates complex regulation at the 34.5kV bus bar. By analyzing the system's load curves, 6 adjustment groups were defined for actuation on specific days and times, thus achieving more accuracy in voltage levels and reduction of approximately 40% in the on-load tap operations.

KEY WORDS

Voltage adjustment relay; energy quality; parameter definition; mixed loads; on-load tap changer.

1. INTRODUCTION

With a concession area formed by 223 municipalities in the State of São Paulo and 5, in Mato Grosso do Sul, addressing 1.9 million clients, ELEKTRO started its operations in 1998, during the privatization of CESP's energy distribution area.

ELEKTRO covers an area of more than 120 thousand square kilometers, equivalent to 37% of the total area of the State of São Paulo, so that the company client profile ranges from industries, commercial ventures to homes often geographically distant but linked to the same distribution mains. As a result, the consumption characteristics show major variations as a function of time of the day and day of the week, including changes in the daily load profile and significant displacements of load centers.

In this context, resolution 505 of ANEEL¹, published on 26/11/2001, targets assuring every client along the electric energy distribution network delivery of voltage within adequate limits, and to this end, defines the levels considered acceptable, precarious or critical for the voltage delivered (Service Voltage), in addition to indicators and limits for the time voltage falls outside the acceptable boundaries. These indicators become stricter at every year, until the definitive minimum values are reached in 2007.

The approach traditionally deployed by ELEKTRO to endeavor to address the dispositions set out in resolution 505 was using LDC - Line Drop Compensation, present in nearly 100% of the voltage regulation relays found on the market today. In some situations, however, this approach did not offer satisfactory results, due to the seasonal changes resulting from the consumer profile or changes in the configurations of the electric energy system in maneuver situations or yet, due to specific load characteristics for typical days when, during the day, the load is strongly industrial in certain portions of electrical regions (industrial districts) and, at peak times, materially residential in other parts of the same electrical region (residential districts).

As a function of this, ELEKTRO realized the need for a voltage regulation system capable of addressing their distribution network's seasonality features, which was achieved in 2004 through work done in partnership with a manufacturer of voltage regulation relay (Treotech). Under this aspect, this article will present the experiences and results obtained both in the initial attempts at solving the problem, as well as application of the new voltage regulation system, which operates based on consideration for load seasonality features.

2. OPERATION OF VOLTAGE REGULATION RELAYS

2.1. Basic Operation of Conventional Relays

Voltage regulation relays operate based on programming for a few basic parameters, as shown in illustration 1.

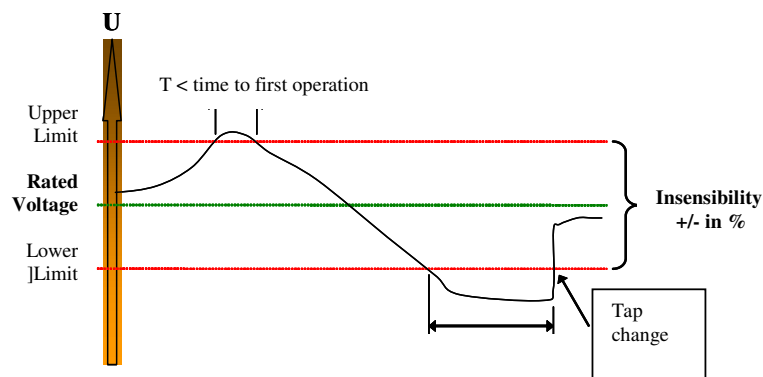

Illustration 1 – Basic operation parameters for voltage regulation relay

The parameters are:

- Rated or reference voltage, which can be referred to the system's actual operating voltage (kV) or to the secondary of the PT (V),
- The insensibility, which is the acceptable tolerance range for voltage above and below the reference voltage, usually defined as a percentage of it,
- Timing to perform the first tap change after the voltage measured remains for a given time, usually in seconds, above the upper or below the lower limits.

The timing mentioned above can also be programmed for operation by:

- Time Set, where the delay in changing taps is always the same (the value adjusted in seconds), regardless of the magnitude of the voltage deviation, or

- Inverse Time, where the delay in changing taps (t) is the same as the adjusted value (T) multiplied by a reduction factor inversely proportional to the magnitude of the voltage deviation (ΔU) in relation to the adjustment for insensibility (Ins), as shown in equation 1:

$$t = T \cdot (Ins / \Delta U) \quad (1)$$

Programming the parameters above would already be enough to ensure good voltage regulation at the substation bus bar and for any loads located geographically close to it. However, for more distant loads, drops in resistive and inductive resistances in conductors may cause final voltage levels to fall below the lower threshold allowed, especially when load currents are higher, as shown in illustration 2. For this reason, most voltage regulation relays are also equipped with load current measuring devices with adjustments for line voltage drops.

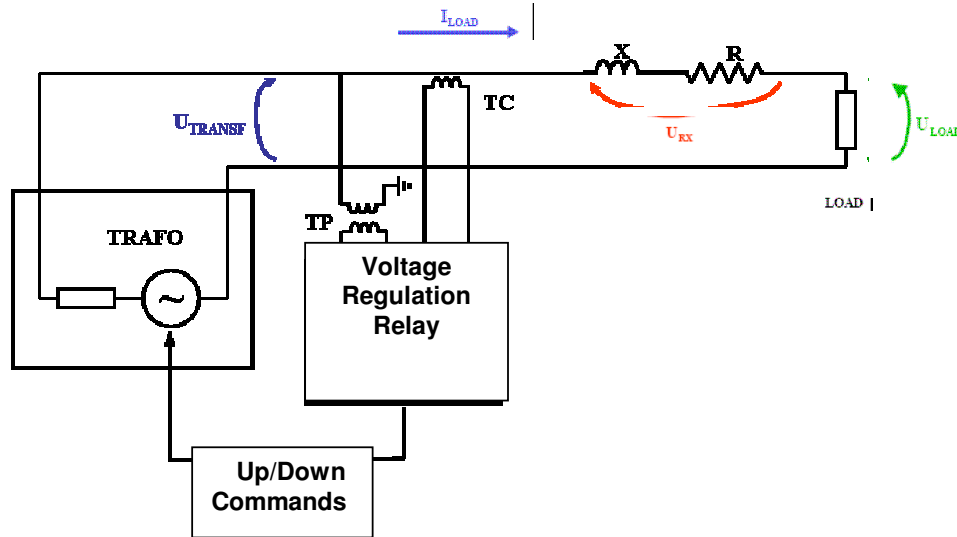

Illustration 2 – Line voltage drop and load voltage

Since the ideal situation shown in the illustration above is not found on most practical applications, with the load being concentrated on a single point, the usual procedure implies in adopting a fictitious load center, which is a point along the line where it is considered that all the loads are concentrated. Based on the location attributed to this point line voltage drop compensation parameters are then calculated. The result is such that, at this specific point, the voltage will be close to the regulation relay and maintained close to the rated value. For the other points in the network, there may be variations, however, if the load center is adequately chosen (and if the network characteristics allow it) these variations will remain within the limits defined by the upper and lower threshold limits.

2.2. Limitations of the conventional approach

2.2.1. Bad voltage regulation at peak times due to drag effect

As mentioned above in item 2.1, voltage regulation relays operate based on tap changes in the commutator after a deviation is detected between the voltage measured and the rated voltage higher than the level of insensibility set, to which we must add a time lag before tap changes in order to avoid unnecessary changes caused by instant voltage deviations. During the periods when the load remains constant or varies slowly, this approach has proven to be suitable.

However, at peak times, when loads tend to shift fairly quickly, both increasing and decreasing, there is what is known as the “drag” effect, shown in illustration 3. The chart shows what happens when average voltage remains below rated voltage when the load is rising, which begins around 5:30 pm,

exactly when a higher voltage would be required, and the opposite occurs when the load decreases, when average voltage remains higher than rated voltage. In addition to this, we can see an increase in periods when voltage is higher or lower than the permissible thresholds, which contributes to worse quality indicators than values established in ANEEL's resolution 505.

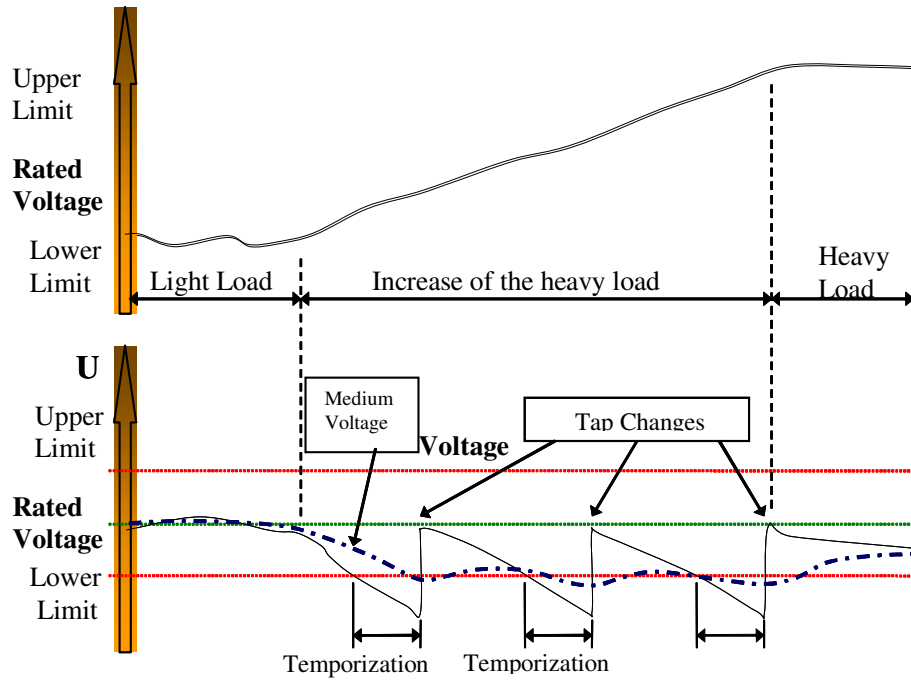

Illustration 3 – Drag effect during peak times

One possible solution for this problem would be to reduce the settings for the insensibility and timer values for the voltage regulation relay, in order to make their actuation more agile in these periods of fast variations in load levels. However, this solution has the severe inconvenience of increasing sharply the number of operations performed by the on-load tap changer throughout the day, even in periods where these changes would not be necessary. Consequences of this include higher maintenance cost for the equipment, since maintenance intervals are determined by the number of operations, increased equipment unavailability periods due to increased maintenance frequency and increased failure risk, considering that the on-load tap changer is one of the main sources of defects in transformers.

2.2.2. *Inefficient compensation of line voltage drop due to displacement of load center*

As mentioned in item 2.1, the use of compensation for line voltage drop requires definition of a load center which represents the load connected to the distribution network. This process can be applied successfully in networks where the load center remains practically unchanged over time. This hypothesis has good chances of being true when the majority of the loads hooked to the network are of similar natures, such as for instance, exclusively residential sector, where maximum load with a given threshold occurs between 6 and 8 pm, or else exclusively industrial, where usually maximum loads at another threshold occur between 7 am and 5 pm.

However, for distribution networks with mixed loads, mixing, for example, residential and industrial loads, the load center can undergo significant displacements depending on the day of the week or even of the time of the day. In these cases, the use of conventional voltage regulation relays and line voltage drop compensation, described in item 2.1 above, do not bring about satisfactory results, bearing in mind that calculations and parameter definitions are carried out considering predominance of one type of load (industrial, for example) which will cause excessively high or low voltages when the load type changes.

It may also happen in cases where the industrial load is higher than the residential one, that total demand during the time in which industries are active, i.e., up to about 5 pm, is higher than for the period when the residential load is predominant, from 6 to 8 pm. In this period, which is when residential loads reach their consumption peak, voltage at the substation bus bar should be kept high, bearing in mind that secondary networks are more loaded and therefore with the highest level of voltage drop. However, since total demand was reduced, the compensation for line voltage drop will reduce the voltage at the substation bus bar, so that residential loads might then receive voltage below minimum permissible values.

2.2.3. Addressing quality indicators of ANEEL resolution 505

ANEEL resolution 505, in addition to specifying the acceptable voltage supply limits, also establishes indicators and their values for the time that the voltage remains at precarious and critical levels. Since voltage levels considered precarious or critical are different for voltages above and below rated, so can the times permissible for voltage deviations be different dependent on direction of deviation. This way, conventional relays would force timer programming according to the shortest of these times, which would lead to the commuter performing unnecessary operations in the opposite situation, with the same inconveniences already previously mentioned in terms of increased maintenance costs for the equipment, increased equipment unavailability periods due to increased maintenance frequency as well as increased failure risk.

2.3. Solution using multi-parameter regulation relay

The shortcomings in the conventional approach, as stated above, led ELEKTRO, in 2004, to search the market for a solution that would deal with the difficulties mentioned, which was solved by contacting a national voltage regulation relay manufacturer. The contact established resulted in developing a relay that is capable of simultaneous multiple parameter definitions and flexible programming.

2.3.1. Adjusting the multiple parameter definitions

In relation to the multiple parameter definitions, the relay that was developed has the following features:

- Six complete and independent sets of parameters for voltage regulation, with each set being comprised of the following individual settings:
 - Rated voltage
 - Insensibility
 - Time to first operation
 - Type of timing (time Defined or Inverse)
 - Resistive line voltage drop
 - Reactive line voltage drop
 - Percentage line voltage drop
 - Limit for raising maximum voltage to compensate for line voltage drop.
- Selection of set of parameters to be used in regulating voltage by:

- Programming day(s) of the week (from Sunday to Saturday) when each set should be applied, complemented by time for beginning and end of actuation for that set of parameters, or
- Remote set selection through dry contact inputs.
- Internal clock with day, month, year, hour, minute, second and day of the week, with maintenance of clock set in case of lack of power feed without using internal batteries.

Using relays with multiple parameter set capability offers the following benefits for voltage regulation:

- The drag effect can be materially minimized, once different insensibility ranges can be set for the different times of the day, so that in low load variation periods, like the time period from midnight on or even during the day, can have broader insensibility bands with longer timing intervals, while in time periods when load variations are sharper and more sudden, such as peak time, narrower insensibility bands can be used with shorter timing intervals. This also avoids the increase in number of on-load tap change operations, which can actually be reduced, once the gain in number of operations obtained during most of the day at least offsets the increased operation frequency during peak times, and may even exceed this.
- Line voltage drop compensation can also be optimized, through programming adequate values for resistive and reactive line voltage drops to meet the effective location of the load center, taking into account the center’s displacement due to mixed loads (industrial and residential) which hook up and disconnect from the system depending on the day of the week and the time of day.

2.3.2. Flexible timing adjustments

In addition to the function of multiple parameter definition, the voltage relay that was developed also features the following additional characteristics:

- For each set of regulation parameters, adjustment of 3 timing interval values for first tap change, with each timing interval being associated to a range of deviation of measured voltage in relation to rated
- Each timing interval adjustment is further subdivided into 2 independent settings: 1 for voltage below minimum threshold and one for voltage above the maximum threshold.

Table 1 gives an example of timing interval parameter definition. It is important to observe that the settings used as examples in this table are repeated for each set of parameters for voltage regulation, allowing for different timing settings for each set.

Table 1 – Example of parameter definition for time interval to first tap change

Voltage deviation range	Up to 5%	5% to 8%	8 to 10%	Above 10%
Time to raise voltage	∞	90 seconds	30 seconds	10 seconds
Time to lower voltage	∞	30 seconds	10 seconds	3 seconds

Using relays equipped with flexible timing settings offers the following benefits to voltage regulation:

- Facilitates adapting voltage supplied to ANEEL resolution 505, by allowing independent timing settings for each voltage deviation range, avoiding exceeding limit values for the indicators for time voltage remains in precarious and critical levels.
- Avoids unnecessary increases in number of OLTC operations by allowing different operation timing settings when direction of deviation is above or below rated voltage, which avoids having to define timing programming according to the shortest permissible time intervals.

3. INSTALLING THE NEW REGULATION RELAY AT THE BJP SUBSTATION

The Bom Jesus dos Perdões (BJP) substations feeds the city of Piracaia through two, 138/34.5kV 12.5MVA transformers, equipped with on-load tap changer, and one 17-km 34.5kV line as shown in the single line diagram of illustration 4.

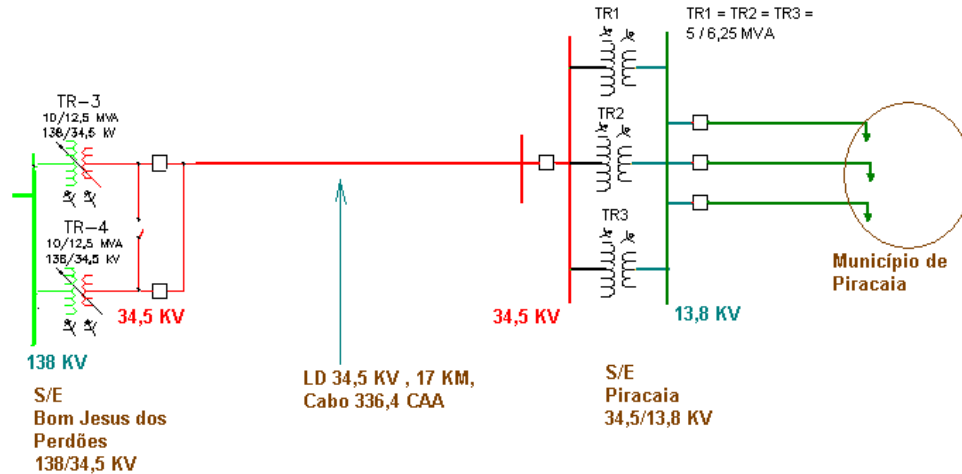

Illustration 4 – Simplified single line diagram for substations BJP and Piracaia

At a first analysis, regulation of the bus bar at the Piracaia S/S could be the ideal solution for this system. However, due to the maximum demand for this S/S and the current configuration, the three (03) 34.5/13.8kV 6.25MVA transformers would have to be replaced by 2 self-regulated 15 MVA transformers, which would result in high level of investment. So, a choice was made to manage voltage over the length of the system using a multiple parameter relay, which has proven to be effective at a much lower cost.

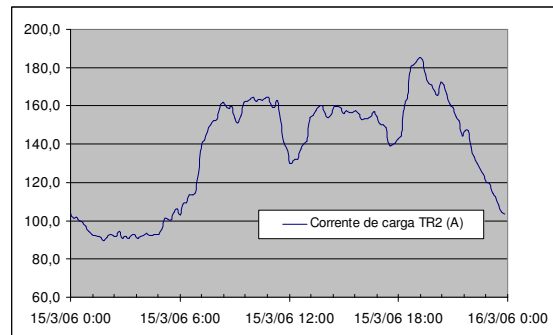

Illustration 5 – Characteristic of load at Piracaia SS

This line's industrial and residential nature can be seen in illustration 5, where it can also be seen that there is no predominance of industrial load over residential load. Because of this, this facility had no problems directly related to line voltage drop compensation when the industrial load portion was disconnected (item 2.2.2). There were, however, issues related to deficient voltage regulation during peak periods, as explained in item 2.2.1 above. These issues were settled using the new voltage regulation relay with adequate parameter definition, as shown in table 2. Results obtained are shown in item 4.

Table 2 – Parameter definition for the new voltage regulation relay at SS BJP

	Set 1	Set 2	Set 3	Set 4	Set 5	Set 6
Day of the week	-----	Mon. to Saturday	Mon. to Saturday	Mon. to Saturday	Sunday	Sunday
Beginning time	-----	07:00:00	17:30:00	21:00:00	17:30:00	20:30:00
End time	-----	17:29:00	20:59:00	23:59:00	20:29:00	22:59:00
Rated voltage	113.3 V	116.0 V	117.3 V	115.3 V	116.0 V	114.6 V
Timing type	Linear	Linear	Linear	Linear	Linear	Linear
Subsequent timing	03 sec	03 sec	03 sec	03 sec	03 sec	03 sec
Drop Comp. Type	Deactivated	Deactivated	Deactivated	Deactivated	Deactivated	Deactivated
Voltage drop Ur	0 V	0 V	0 V	0 V	0 V	0 V
Voltage drop Ux	0 V	0 V	0 V	0 V	0 V	0 V
Compensation Z	0 V	0 V	0 V	0 V	0 V	0 V
Compensation threshold	20 %	20 %	20 %	20 %	20 %	20 %
Timing / Deviation 1	1.1 %	1.1 %	0.9 %	0.9 %	0.9 %	0.9 %
Time to raise 1	110 sec	90 sec	70 sec	70 sec	70 sec	70 sec
Time to lower 1	110 sec	90 sec	70 sec	70 sec	70 sec	70 sec
Timing / Deviation 2	2.5 %	2.2 %	2.0 %	2.0 %	2.0 %	2.0 %
Time to raise 2	50 sec	50 sec	50 sec	50 sec	50 sec	50 sec
Time to lower 2	50 sec	50 sec	50 sec	50 sec	50 sec	50 sec
Timing / Deviation 3	4.0 %	4.0 %	4.0 %	4.0 %	4.0 %	4.0 %
Time to raise 3	10 sec	10 sec	10 sec	10 sec	10 sec	10 sec
Time to lower 3	5 sec	5 sec	5 sec	5 sec	5 sec	5 sec

Since both 138/34.5kV transformers at BJP SS operate in parallel in the master-slave method, the new regulation relay was installed on one of the transformers, in order to control simultaneously the OLTCs of both transformers.

4. RESULTS OBTAINED

4.1. Voltage regulation

In the case of the Piracaia substation, object of this paper, the main problem found in deploying conventional voltage regulation was low voltages events when the peak loads came on line, caused by the drag effect as explained in item 2.2.1. This fact can be observed in illustration 6, where an example is given of readings taken before the new voltage regulation relay with multiple parameter definition was installed.

The results achieved after installing the new relay are shown in illustration 7, where it can be seen that at the onset of peak load period, voltage is maintained at higher levels due to specific programming created for 5:30h to 8:59 pm time sloth (see table 2, column “Set 3”).

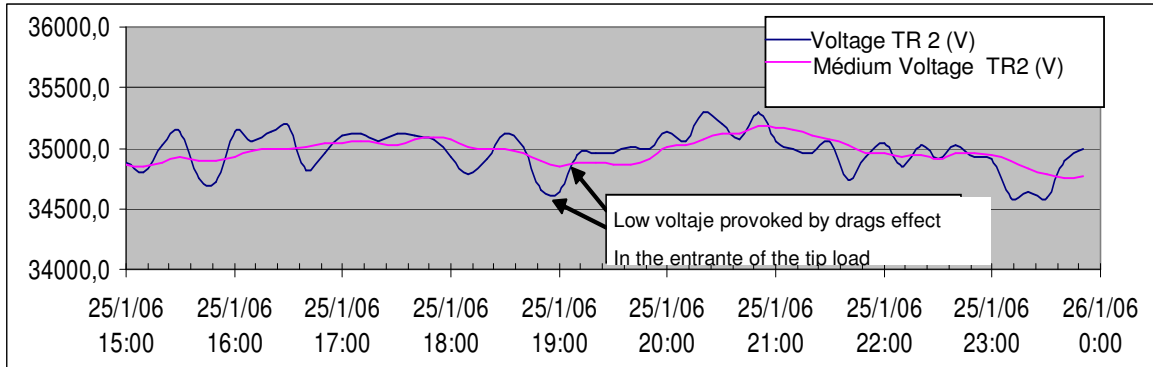

Illustration 6 – Voltage at Piracaia SS at peak times with conventional voltage regulation

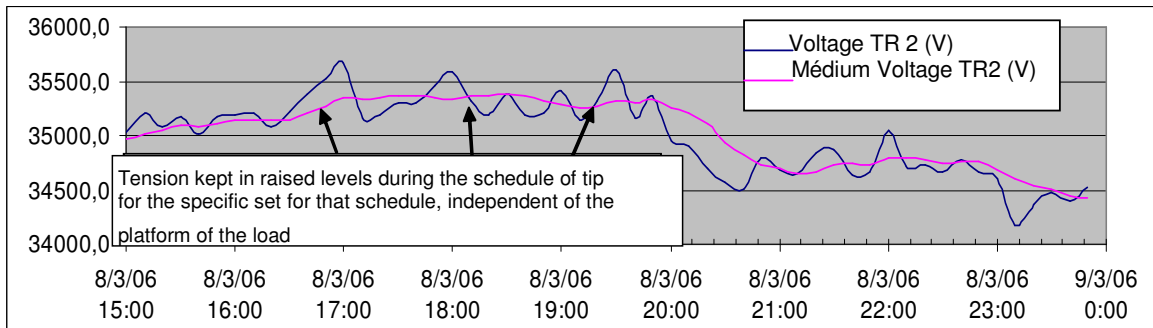

Illustration 7 – Voltage at Piracaia SS at peak times with new voltage regulation relay

4.2. Maintenance of on-load tap changer

One important benefit stemming from using the new voltage regulation relay with multiple parameter definitions, in addition to improved voltage regulation, is the possibility of concentrating the operations of the OLTC on given days and times, following the concept of saving in some moments to spend in others where tap changes are really necessary.

This can be seen in table 3 below, where part of the parameter definition used for the relay is displayed. During the times where there is more load variation, when regulation must occur quickly and accurately, which fall from Monday to Saturday from 5:30 to 11:59 pm and on Sundays from 5:30 to 10:59 pm, the relay operates with insensibility (dead range) of 0.9% and timing of 70 seconds to raise or lower voltage. On the other times, that is from Monday to Saturday from 0:00 to 6:59 am and on Sundays from 11:00 pm to 5:29 pm, the relay operates with increased insensibility and timing of 1.1% and 110 seconds, respectively.

Table 3 – Parameter definition for the new voltage regulation relay at BJP SS

	Set 1	Set 2	Set 3	Set 4	Set 5	Set 6
Day of the week	-----	Mon. to Saturday	Mon. to Saturday	Mon. to Saturday	Sunday	Sunday
Beginning time	-----	07:00:00	17:30:00	21:00:00	17:30:00	20:30:00
End time	-----	17:29:00	20:59:00	23:59:00	20:29:00	22:59:00
Timing / Deviation 1	1.1 %	1.1 %	0.9 %	0.9 %	0.9 %	0.9 %
Time to raise 1	110 sec	90 sec	70 sec	70 sec	70 sec	70 sec
Time to lower 1	110 sec	90 sec	70 sec	70 sec	70 sec	70 sec

The results achieved by this setting adjustment philosophy can be seen in table 4, where the monthly tap change operation survey results are displayed. From December 2004 to January 2006, when regulation was performed by a conventional relay, the number of monthly tap changes was never less than 738, reaching peaks of nearly 1500 operations/month in the last year. On the other hand, the latest data sets, after installing the new regulation relay in February 06, 2006, indicates a reduction in the number of tap changes down to around 420, a reduction on the order of 40%, even in relation to the best result obtained previously with conventional regulation.

Table 4 – Number of tap changes using a conventional relay and with a multiple parameter relay

Month	Year	Counter	Operations Month	Operations Aggregate
2	2006	19177	423	90573
1		18754	824	90150
12	2005	17930	754	89326
11		17176	738	88572
10		16438	1211	87834
9		15227	1201	86623
8		14026	1194	85422
7		12832	1192	84228
6		11640	1488	83036
5		10152	1019	81548
4		9133	765	80529
3		8368	1168	79764
2		7200	1218	78596
1		5982	1884	77378
12	2004	4098	832	75494

← Reduction on the order of 40% in number of tap changes

5. CONCLUSIONS AND RECOMMENDATIONS

The experience obtained from applying the new voltage regulation relay with multiple parameter definitions has shown that adopting this new philosophy can bring about material gains in different aspects.

First, there were gains for clients in the quality of the voltage regulation process, which in the case in point was the result of the possibility offered by specific parameter definition for each time slot. This allowed the voltage regulation relay to operate on different voltage thresholds according to the load situation of the residential portion, even with the industrial portion operating at light load regime, like for instance peak time on Sundays.

Additionally, as a result of the flexibility afforded by defining parameters for the operation of the relay as a function of days of the week and times of the day, it will be possible to reduce the wear on the OLTCs for the source transformers by significantly reducing the number of operations without sacrificing the quality of the voltage regulation. This will allow programmed maintenance intervals for power transformers to be extended, due to a lower number of changes, simultaneously reducing the failure risk for these transformers, considering that statistically the on load tap changer is by far the biggest source of defects in transformers.

Finally, with the intelligent process of parameter definition suited to the peculiarities of loads characteristics, gains were also obtained by avoiding the need for investments with the replacement of the existing OLTC-less transformers at the 34.5kV S/S, thus also avoiding costs incurred in maintenance for the new equipment with OLTCs.

Good management of voltage regulation for the electrical system, through the functionalities of the voltage regulation relay with multiple parameter definition capability developed here, contributes to moderate tariff setting, helping to ensure fair tariffs and in particular defending the quality of the service, maintaining voltage supplied to clients within the ranges defined in ANEEL resolution 505/2001.

It is worth highlighting here that the cost for the voltage regulation relay developed here is similar to those for conventional relays, since the improvements were implemented by way of changes in the operating logic, without any significant hardware alterations.

6. BIBLIOGRAPHY

1 ANEEL: RESOLUTION N° 505 - Dispositions related to compliance with levels of voltage in electric energy supplied in permanent regime. Brasília / DF, 26/11/2001, last review on 28/01/2005.